

Item No	drawing no.	description	qty
1	SS80P-03 A	SS80Plus Heatsink Bracket	2
2	SS80P-02 B	SS80Plus Driver Bracket_single	1
3	SS150-V2-02 A	SS150-V2 U Type Bracket_single	1
4	SS80P-05 A	M5-16L screw	6
8	SS80P-04 A	M5-12L screw	4
9	SS80P-06 A	M10-20L screw	4

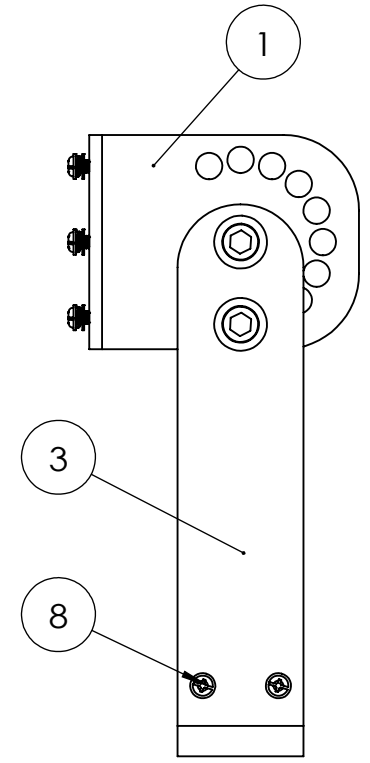

note:  
 1. black color  
 2.part no.:CT-SS150V20AB2001

MARK	DESCRIPTION	DATE	APPROVED
2			
1			
REVISION			

	MET.SPEC.	UNSPECIFIED TOL'S	MODEL NO:
	SUS201 SPCC SUS304	0.5~6 ±0.50 6~30 ±1.0 30~120 ±1.50 120~315 ±2.0	SS150-V2
APPROVED BY	2018/5/22	UNIT	DRAWING NAME
CHECKED BY	2018/5/22	mm	SS150-V2 Single Unit Kit
DESIGN BY	2018/5/22	SCALE	SS150-V2 一對一支架總成圖
DRAWN BY	Justin	1:3	DRAWING NO.
	2018/5/22	SIZE	RH03a31
		A4	REV
			A
			SHEET
			1/1

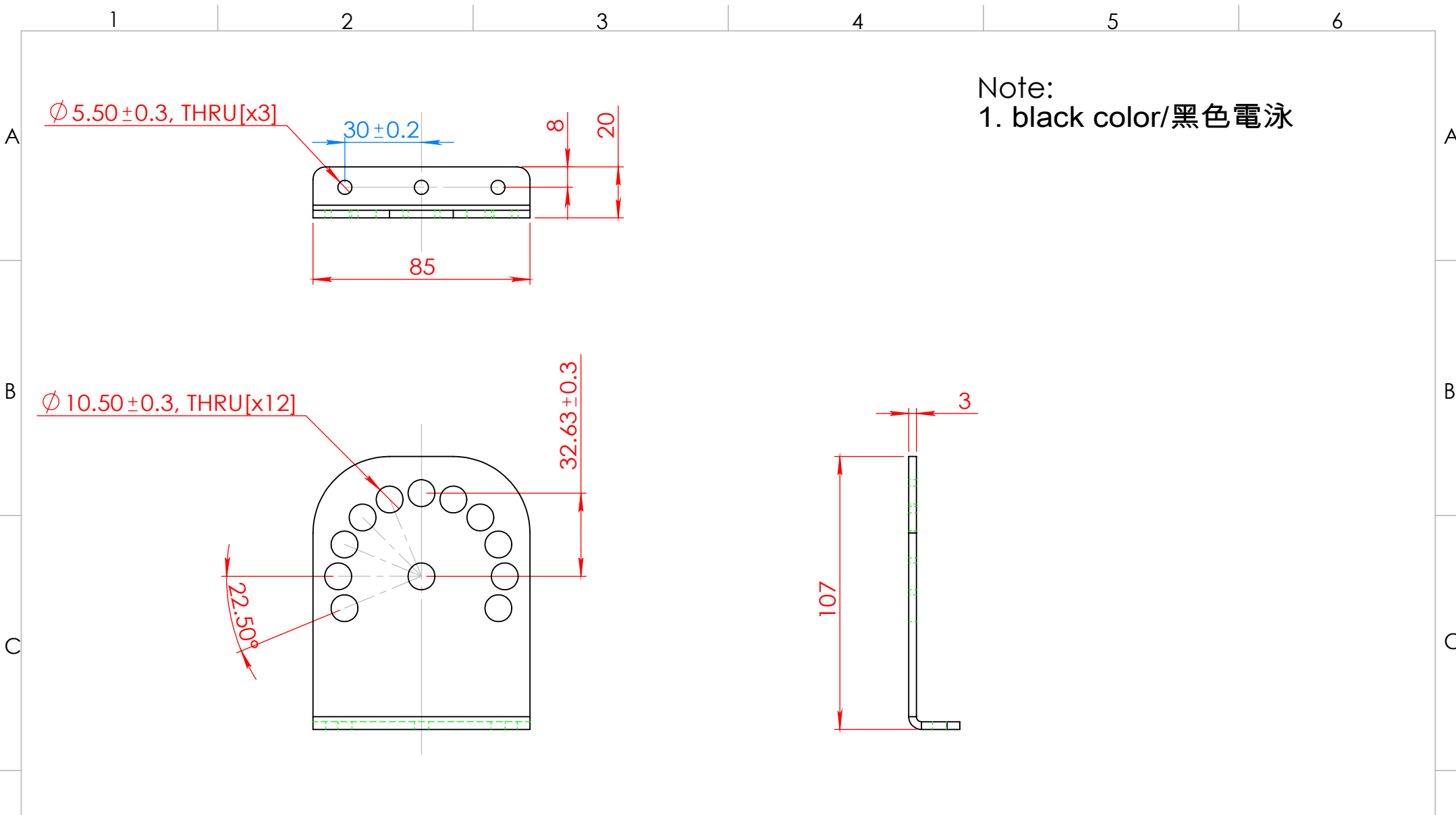

Note:  
1. black color/黑色電泳

 <b>GlacialTech INC</b>				MET.SPEC.	AL1100 T=3.0	UNSPECIFIED TOL'S	MODEL NO:
				UNIT	mm	0.5~6 ±0.5 6~30 ±1.0 30~120 ±1.5	SS80 Plus
APPROVED BY		2017/10/24	DRAWING NAME				
CHECKED BY		2017/10/24	Heatsink Bracket for SS80 Plus Single Unit Kit				
DESIGN BY		2017/10/24	SS80 Plus 1對1散熱片側板				
DRAWN BY	Justin	2017/10/24	SCALE	1:2	DRAWING NO.	REV	SHEET
REVISION			SIZE	A4	SS80P-03	A	1/1

MARK	DESCRIPTION	DATE	APPROVED
2			
1			

1 2 3 4 5 6

A

A

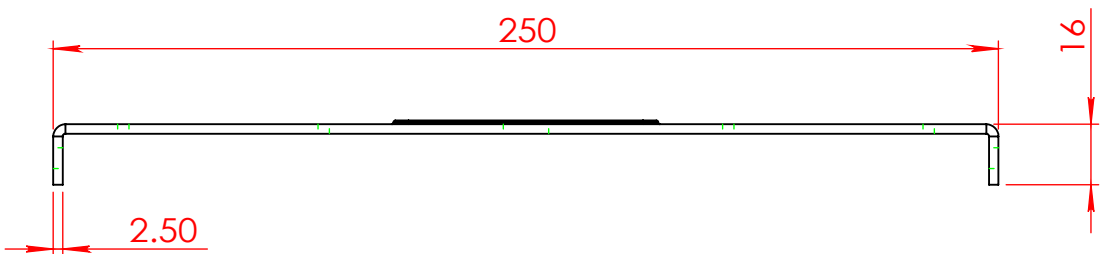

Note:  
1. black color/黑色電泳

B

B

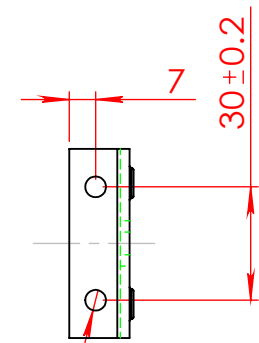
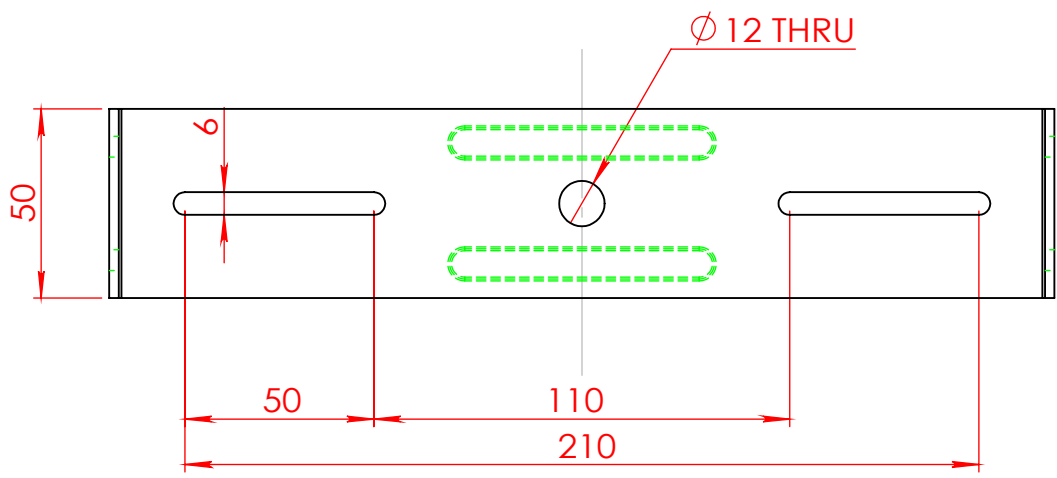

Ø 5.50±0.3, THRU[x4]

C

C

D

D

 <b>GlacialTech INC</b>				MET.SPEC. <b>SPCC</b> T=2.5		UNSPECIFIED TOL'S 0.5-6 ±0.5 6-30 ±1.0 30-120 ±1.5 120-315 ±2.0		MODEL NO: <b>SS80 Plus</b>	
				UNIT mm		DRAWING NAME Driver Bracket for SS80 Plus Single Unit Kit SS80 Plus 1對1電源支架			
APPROVED BY		2018/5/8		SCALE 1:2		DRAWING NO. <b>SS80P-02</b>		REV <b>B</b>	
CHECKED BY		2018/5/8		SIZE A4		SHEET <b>1/1</b>			
DESIGN BY		2018/5/8							
DRAWN BY		Justin		2018/5/8					

MARK	DESCRIPTION	DATE	APPROVED
2			
1			
REVISION			

1 2 3 4 5 6

Note:  
1. 黑色電泳/black Electrophoresis

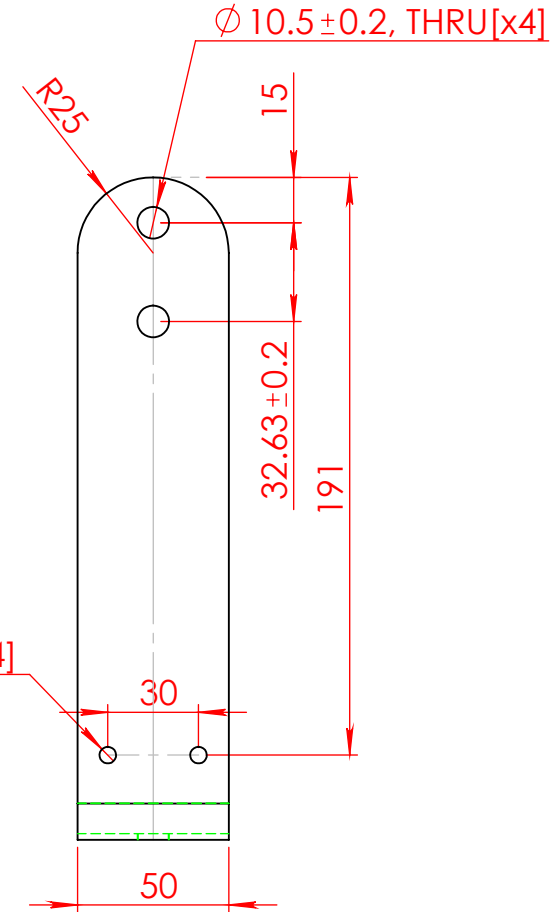
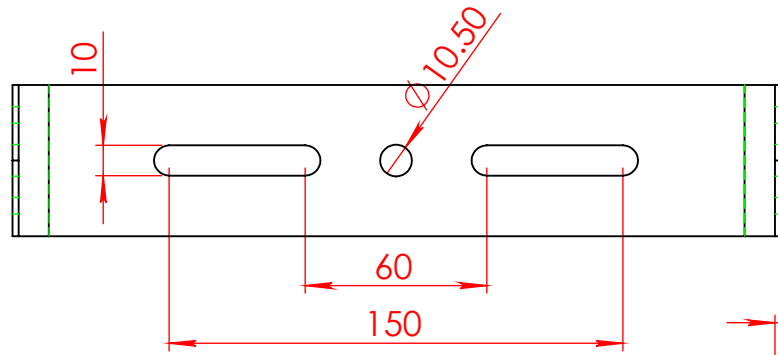

 <b>GlacialTech INC</b>		MET.SPEC.	SUS201	UNSPECIFIED TOL'S	MODEL NO:		
				0.5~6 ±0.50 6~30 ±1.00 30~120 ±1.50 120~315 ±2.00	SS150-V2		
APPROVED BY		2018/5/22	UNIT	mm	DRAWING NAME U Type Bracket for SS150-V2 Single Unit Kit SS150-V2 一對一 U型支架		
CHECKED BY		2018/5/22	SCALE	1:2.5			
DESIGN BY		2018/5/22	SIZE	A4	DRAWING NO.	REV	SHEET
DRAWN BY	Justin	2018/5/22			SS150-V2-02	A	12

MARK	DESCRIPTION	DATE	APPROVED
2			
1			
REVISION			

M5-12L Screw

M5 Flat Washer

M5 Spring Washer

M5 Nut

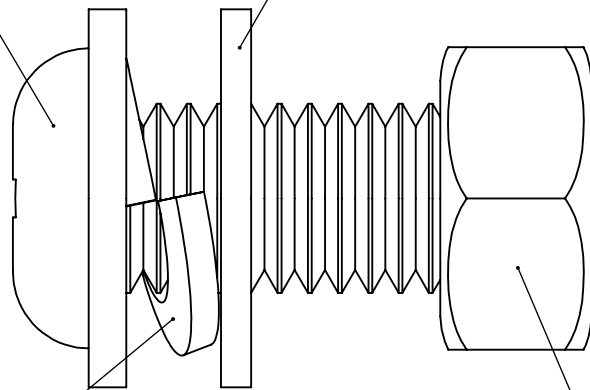

 <b>GlacialTech INC</b>		MET.SPEC. <b>SUS 304</b>	UNSPECIFIED TOL'S X.XX±0.10 XX.XX±0.20 XXX.XX±0.25 ANGULAR±1.00°	MODEL NO: <b>SS80 Plus</b>
APPROVED BY		2017/10/24	UNIT mm	DRAWING NAME <b>M5-12L+Spring Washer+flat Washer+Nut</b> <b>M5-12L螺絲組</b>
CHECKED BY		2017/10/24	SCALE 5:1	
DESIGN BY		2017/10/24	SIZE A4	DRAWING NO. <b>SS80P-04</b>
DRAWN BY	<b>Justin</b>	2017/10/24		REV <b>A</b>
				SHEET <b>1/1</b>

MARK	DESCRIPTION	DATE	APPROVED
2			
1			
REVISION			



M5-16L Screw

M5 Flat Washer

M5 Spring Washer

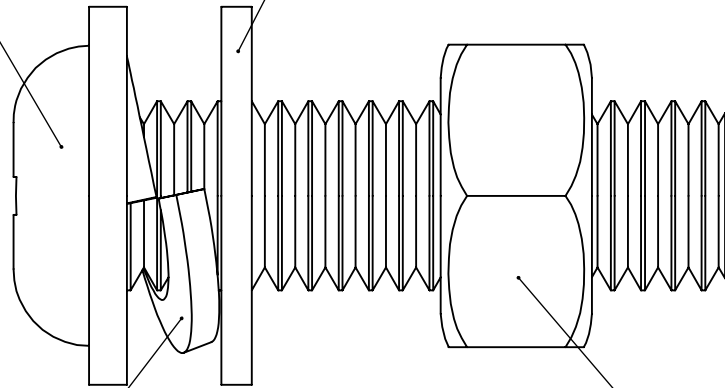
M5 Nut



 <b>GlacialTech INC</b>				MET.SPEC.	UNSPECIFIED TOL'S	MODEL NO:
				SUS304	X.XX±0.10 XX.XX±0.20 XXX.XX±0.25 ANGULAR±1.00°	SS80 Plus
APPROVED BY		2017/10/24	UNIT	mm	DRAWING NAME	
CHECKED BY		2017/10/24			M5-16L+Spring Washer+Flat Washer+Nut	
DESIGN BY		2017/10/24	SCALE	5:1	DRAWING NO.	
DRAWN BY	Justin	2017/10/24	SIZE	A4	SS80P-05	REV
REVISION					A	SHEET
						1/1

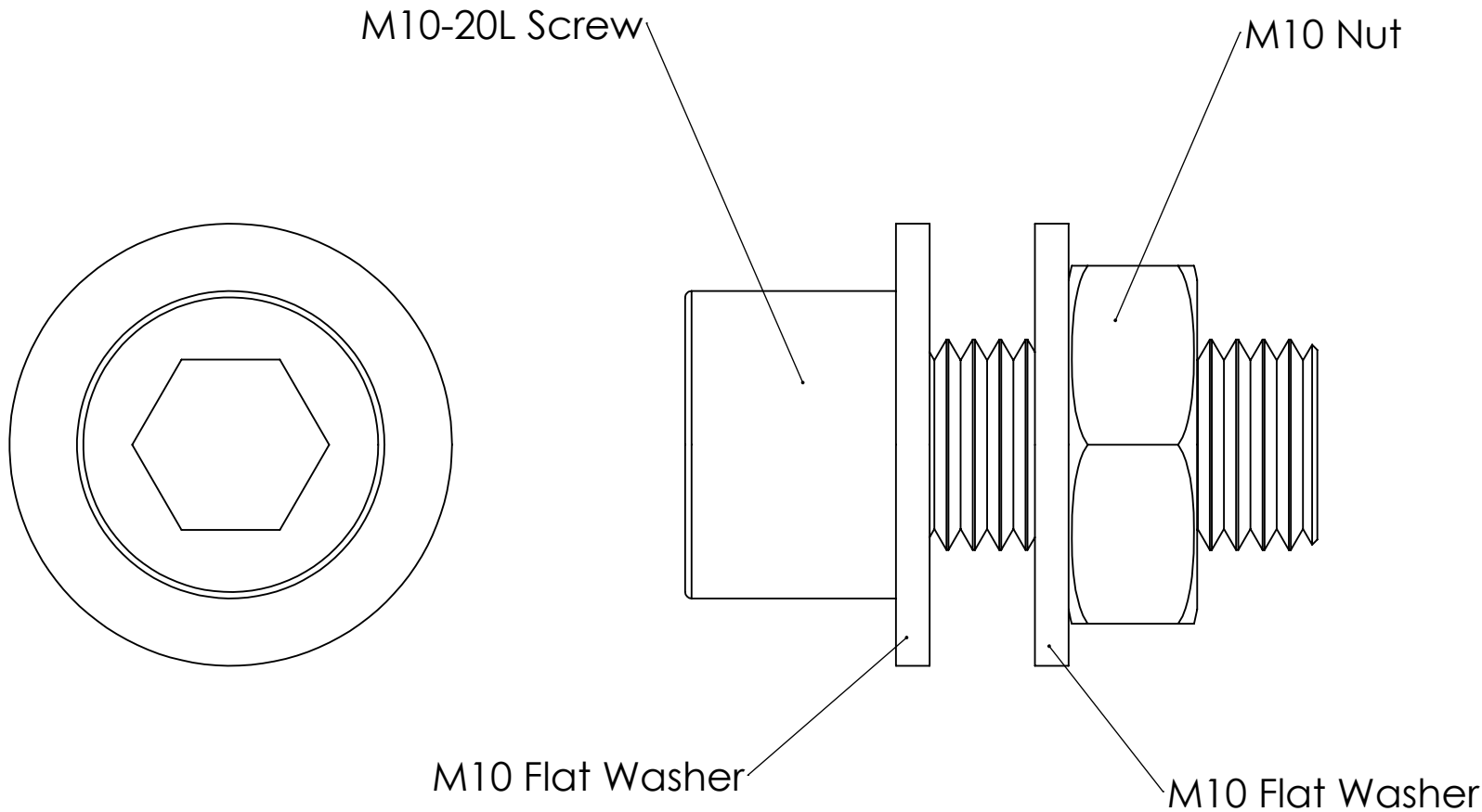

 <b>GlacialTech INC</b>		MET.SPEC. <b>SS304</b>	UNSPECIFIED TOL'S X.XX±0.10 XX.XX±0.20 XXX.XX±0.25 ANGULAR±1.00°	MODEL NO: <b>SS80 Plus</b>
APPROVED BY		2017/10/24	UNIT mm	DRAWING NAME <b>M10-20L+Flat Washer(x2)+Nut</b> <b>M10-20L螺絲組</b>
CHECKED BY		2017/10/24	SCALE 3:1	
DESIGN BY		2017/10/24	SIZE A4	DRAWING NO. <b>SS80P-06</b>
DRAWN BY	<b>Justin</b>	2017/10/24		REV <b>A</b>
				SHEET <b>1/1</b>

MARK	DESCRIPTION	DATE	APPROVED
2			
1			
REVISION			