

1 2 3 4 5 6

A

B

C

D

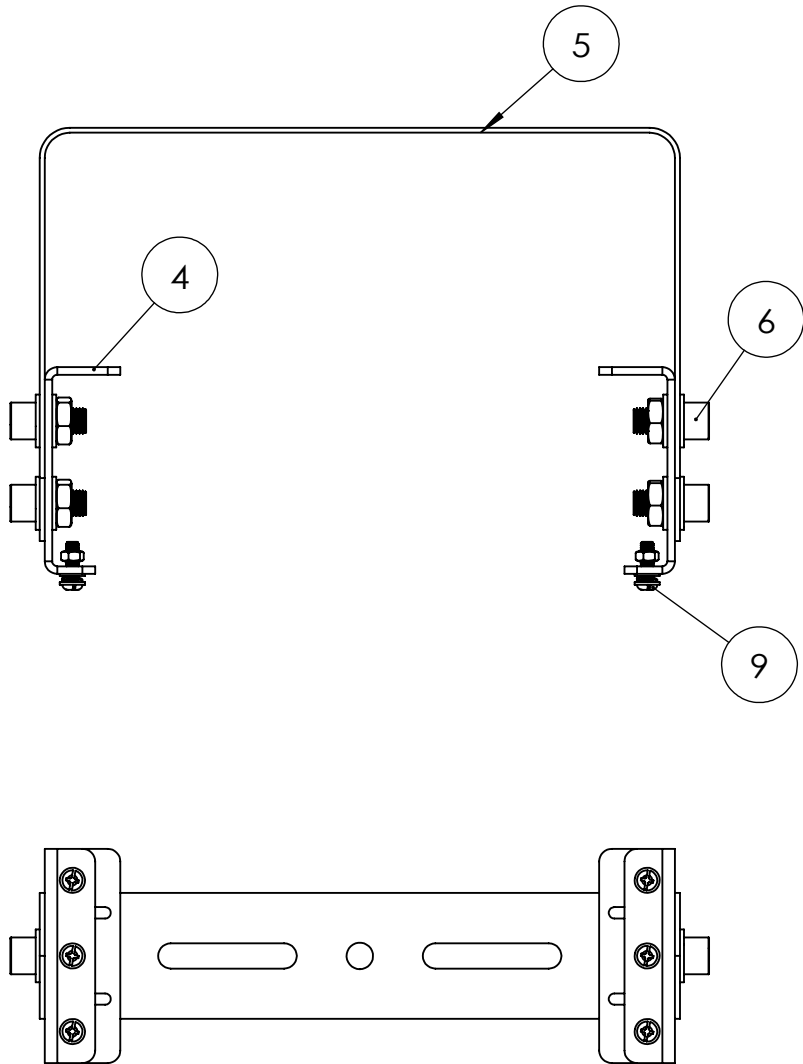

item no.	drawing no.	description	qty
4	SS80-11 A	Side Bracket for SS80 Heatsink	2
5	SS80P-01 B	U Type Bracket for SS80 Plus single Unit Kit	1
6	SS80P-06 A	M10-20L Screw	4
9	SS80P-05 A	M5-16L Screw	6

A

B

C

D

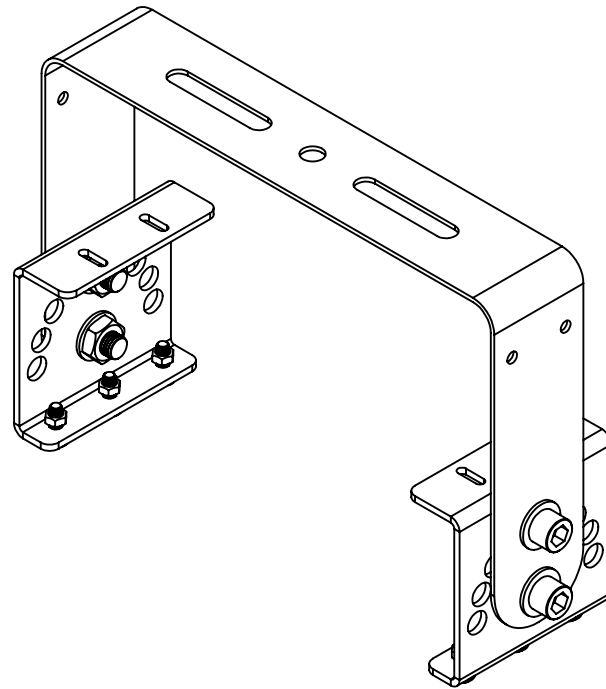

RF03a04

part no.: CT-SS080000AB1001



 GlacialTech INC		MET.SPEC.	UNSPECIFIED TOL'S X.XX±0.10 XX.XX±0.20 XXX.XX±0.25 ANGULAR±1.00°	MODEL NO: SS80
APPROVED BY		2018/1/17	UNIT mm	DRAWING NAME SS80 Single Unit Kit SS80 1對1 支架總成圖
CHECKED BY		2018/1/17	SCALE 1:3	DRAWING NO. SS80a11
DESIGN BY		2018/1/17	SIZE A4	REV A
DRAWN BY	Justin	2018/1/17		SHEET 1/1

MARK	DESCRIPTION	DATE	APPROVED
2			
1			
REVISION			

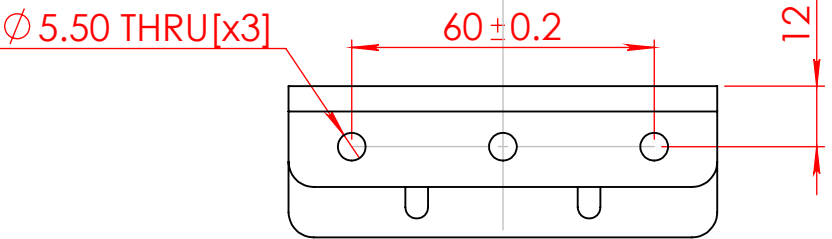
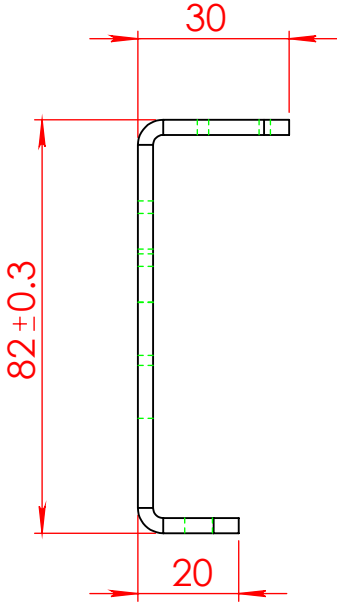
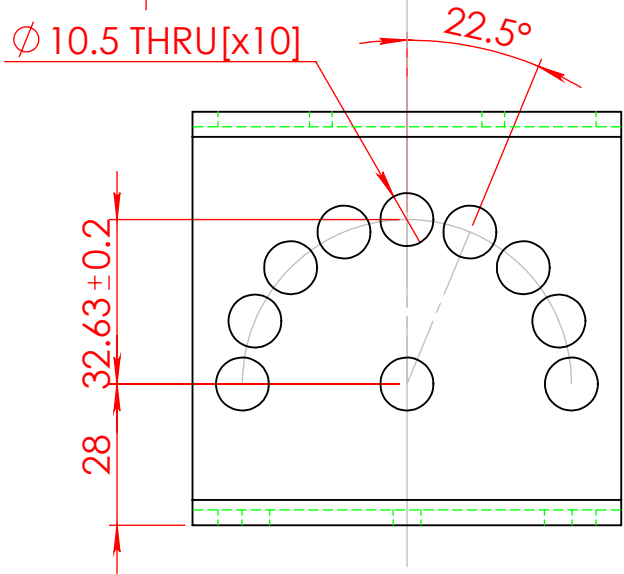
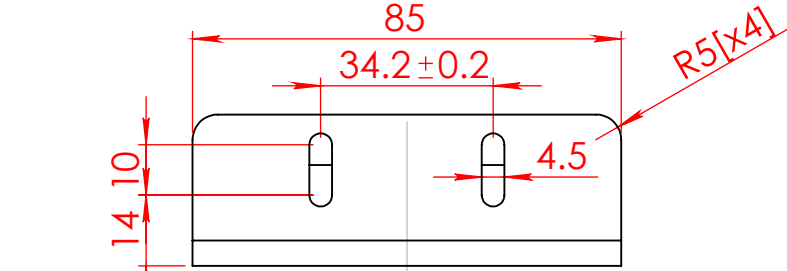
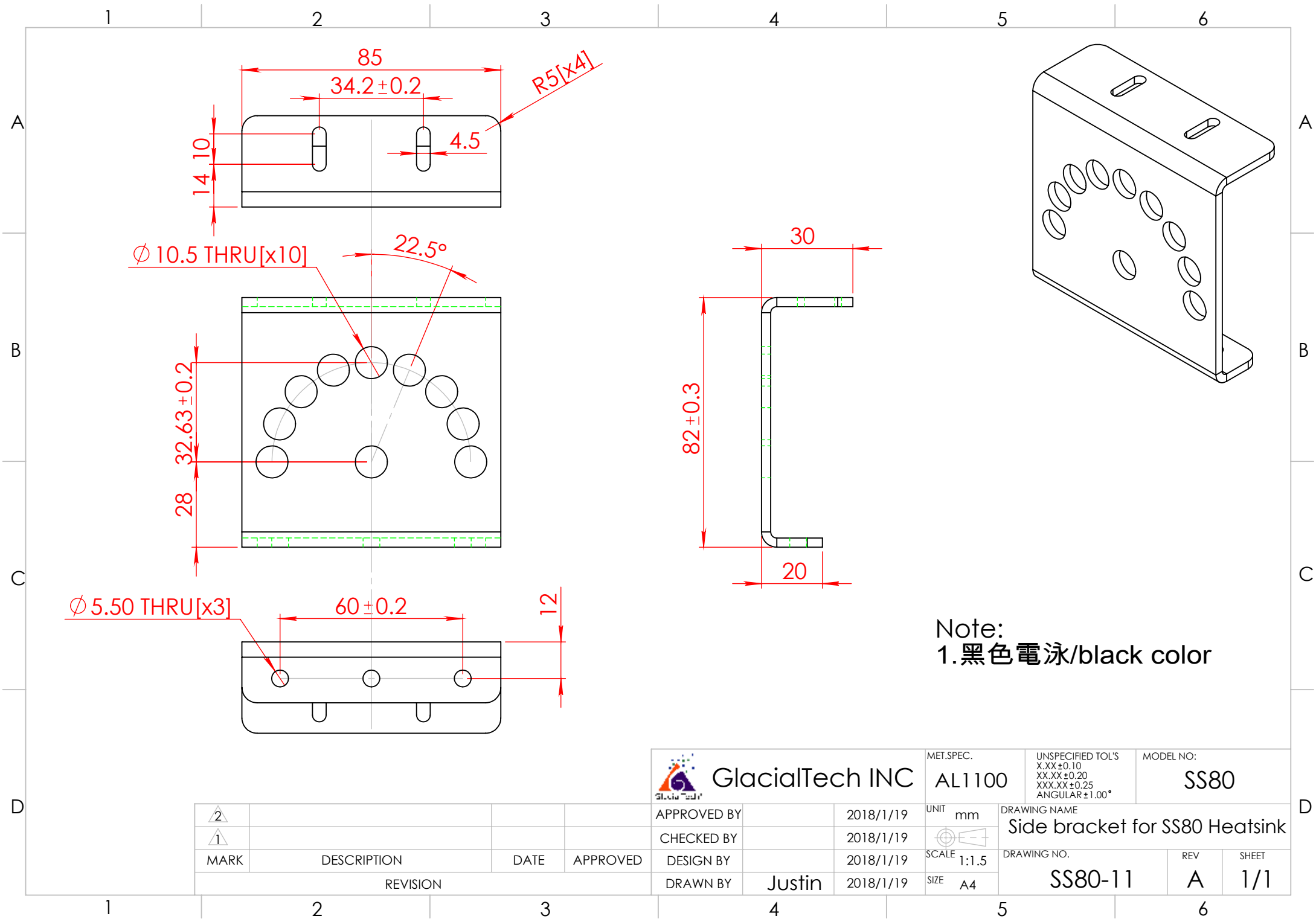
1 2 3 4 5 6





Note:
1. 黑色電泳/black color

 GlacialTech INC		MET.SPEC. AL1100	UNSPECIFIED TOL'S X.XX±0.10 XX.XX±0.20 XXX.XX±0.25 ANGULAR±1.00°	MODEL NO: SS80
APPROVED BY		2018/1/19	UNIT mm	DRAWING NAME
CHECKED BY		2018/1/19		Side bracket for SS80 Heatsink
DESIGN BY		2018/1/19	SCALE 1:1.5	DRAWING NO.
DRAWN BY	Justin	2018/1/19	SIZE A4	SS80-11
				REV A
				SHEET 1/1

MARK	DESCRIPTION	DATE	APPROVED
2			
1			
REVISION			

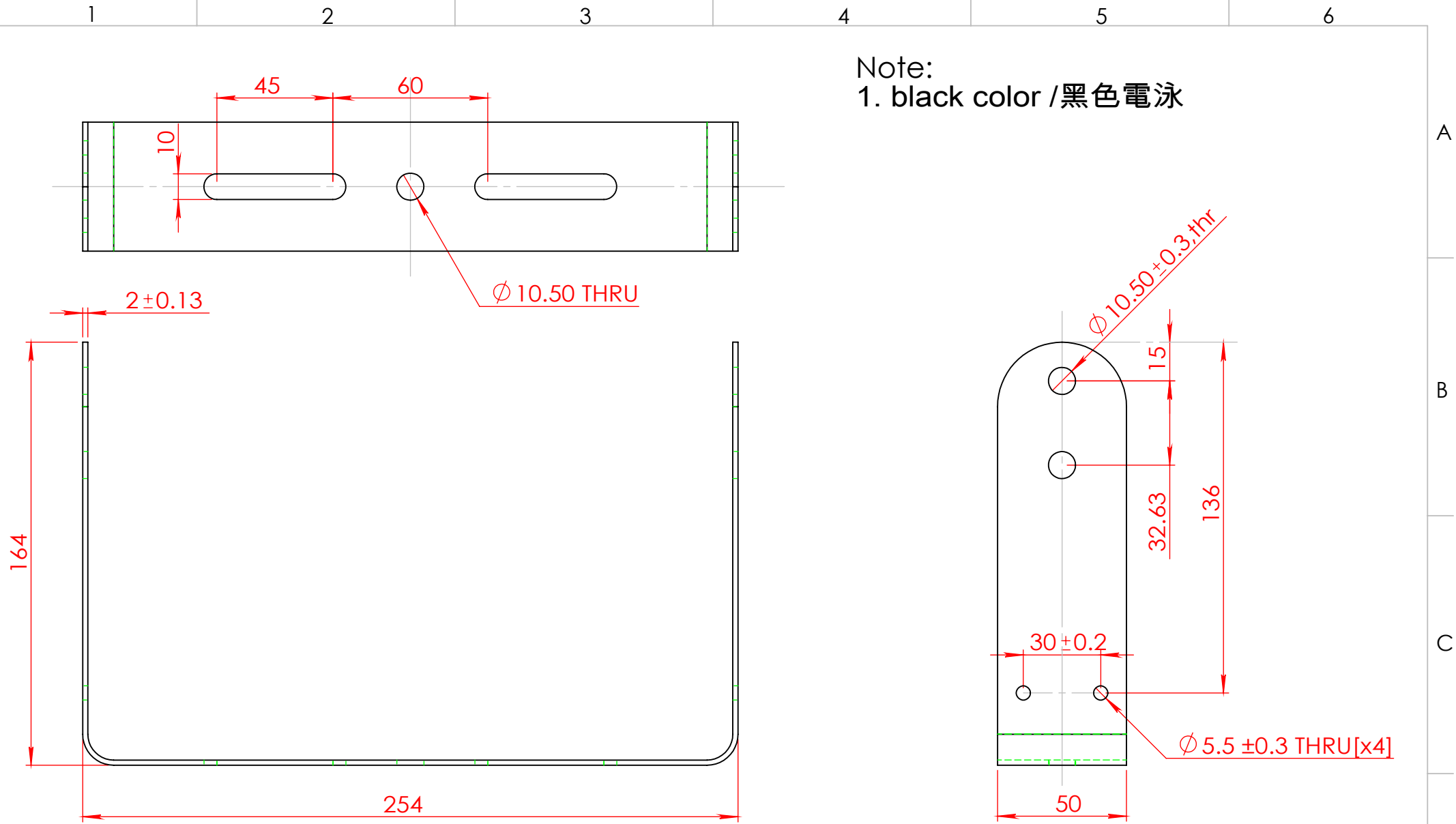
Note:
1. black color / 黑色電泳



 GlacialTech INC		MET.SPEC.	SUS201 T=2.0	UNSPECIFIED TOL'S	0.5-6 ±0.5 6-30 ±1.0 30-120 ±1.5 120-315 ±2.0	MODEL NO:	SS80 Plus
		UNIT	mm	DRAWING NAME		REV	SHEET
APPROVED BY		2017/11/13	 SCALE 1:2	DRAWING NO.		B	1/1
CHECKED BY		2017/11/13		SS80 Plus 1對1 U型支架			
DESIGN BY		2017/11/13	SIZE	A4	SS80P-01		
DRAWN BY	Justin	2017/11/13					

MARK	DESCRIPTION	DATE	APPROVED
2			
1			
REVISION			

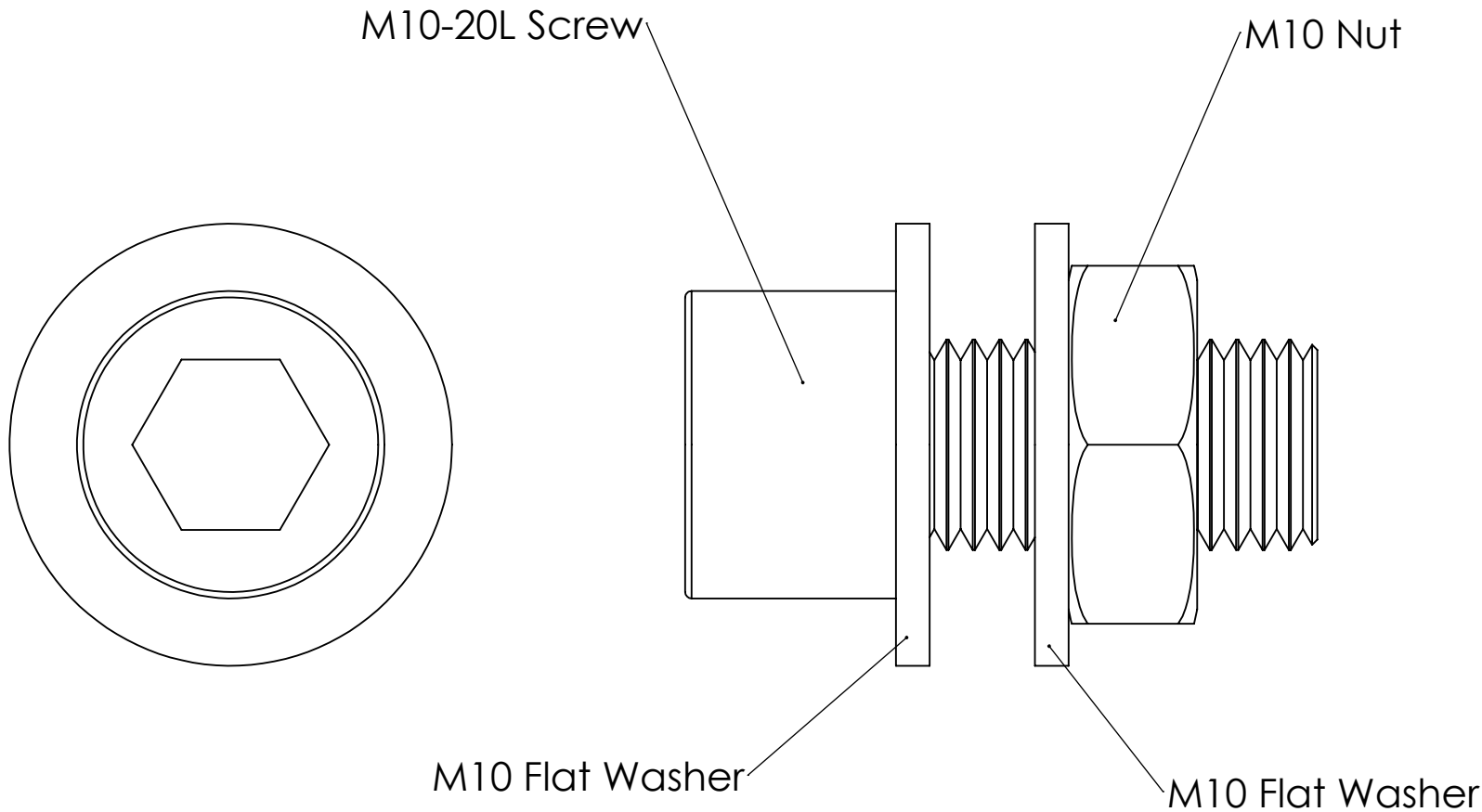

 GlacialTech INC		MET.SPEC. SS304	UNSPECIFIED TOL'S X.XX±0.10 XX.XX±0.20 XXX.XX±0.25 ANGULAR±1.00°	MODEL NO: SS80 Plus
APPROVED BY		2017/10/24	UNIT mm	DRAWING NAME M10-20L+Flat Washer(x2)+Nut M10-20L螺絲組
CHECKED BY		2017/10/24	SCALE 3:1	
DESIGN BY		2017/10/24	SIZE A4	DRAWING NO. SS80P-06
DRAWN BY	Justin	2017/10/24		REV A

MARK	DESCRIPTION	DATE	APPROVED
2			
1			
REVISION			



M5-16L Screw

M5 Flat Washer

M5 Spring Washer

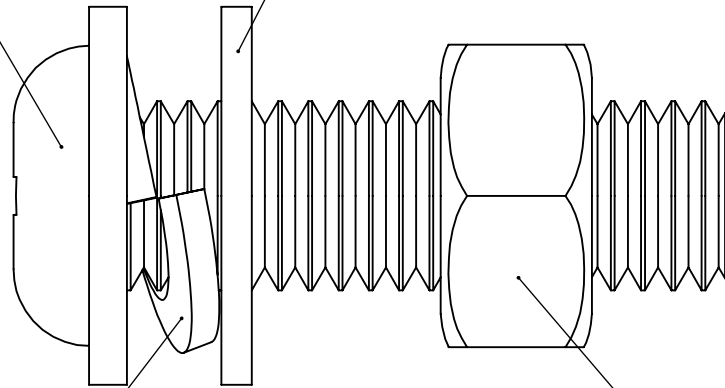
M5 Nut



 GlacialTech INC				MET.SPEC.	UNSPECIFIED TOL'S	MODEL NO:	
				SUS304	X.XX±0.10 XX.XX±0.20 XXX.XX±0.25 ANGULAR±1.00°	SS80 Plus	
APPROVED BY		2017/10/24	UNIT	mm	DRAWING NAME		
CHECKED BY		2017/10/24			M5-16L+Spring Washer+Flat Washer+Nut		
DESIGN BY		2017/10/24	SCALE	5:1	DRAWING NO.		
DRAWN BY	Justin	2017/10/24	SIZE	A4	SS80P-05	REV	SHEET
REVISION					A	1/1	

MARK	DESCRIPTION	DATE	APPROVED
2			
1			