

1 2 3 4 5 6

item no.	drawing no.	description	qty
1	SS80P-01 B	U Type Bracket	1
2	SS80P-02 A	Driver Bracket	1
3	SS80P-03 A	Heatsink Bracket	2
4	SS80P-04 A	M5-12L Screw	4
5	SS80P-05 A	M5-16L Screw	6
6	SS80P-06 A	M10-20L Screw	4

批准
2017.11.14
文管中心

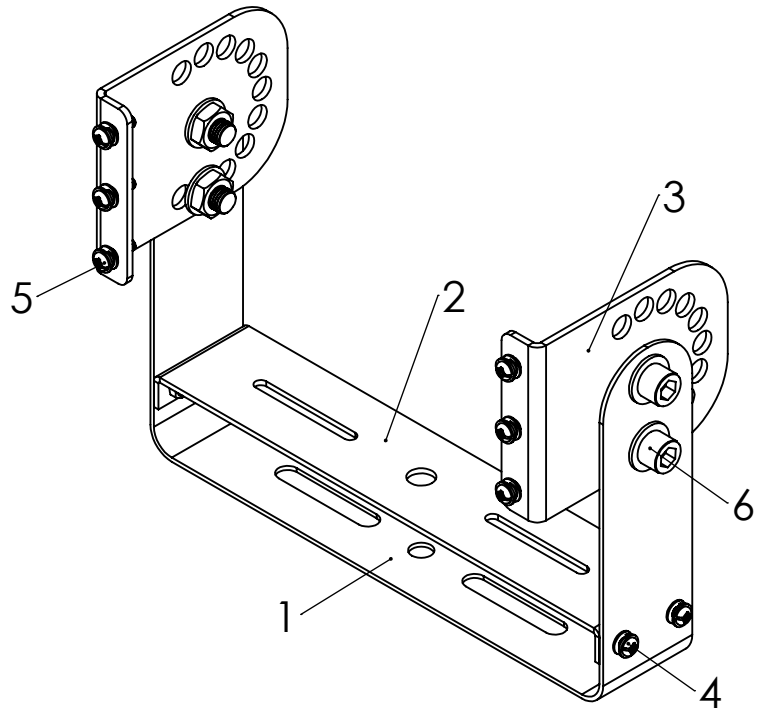
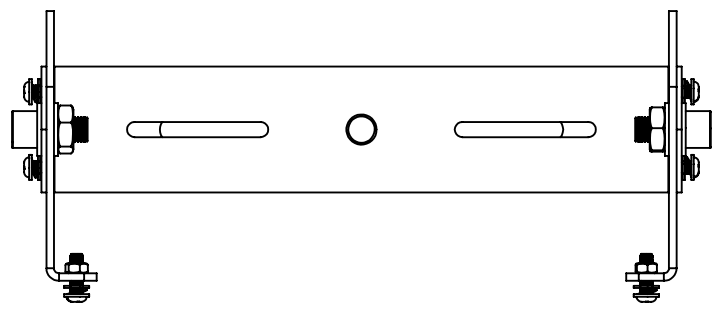

part number: CT-SS80P00AB1001



MARK	DESCRIPTION	DATE	APPROVED
2			
1			
REVISION			

	MET.SPEC.		UNSPECIFIED TOL'S X.XX±0.10 XX.XX±0.20 XXX.XX±0.25 ANGULAR±1.00°		MODEL NO: SS80 Plus	
	APPROVED BY JUSTIN	2017/11/10	UNIT mm	DRAWING NAME SS80 Plus Single Unit Kit SS80 Plus 1對1支架總成圖		
CHECKED BY [Signature]	2017/11/10	SCALE 1:3	DRAWING NO. SS80Pa01		REV B	SHEET 1/1
DESIGN BY Justin	2017/11/10	SIZE A4				

1 2 3 4 5 6

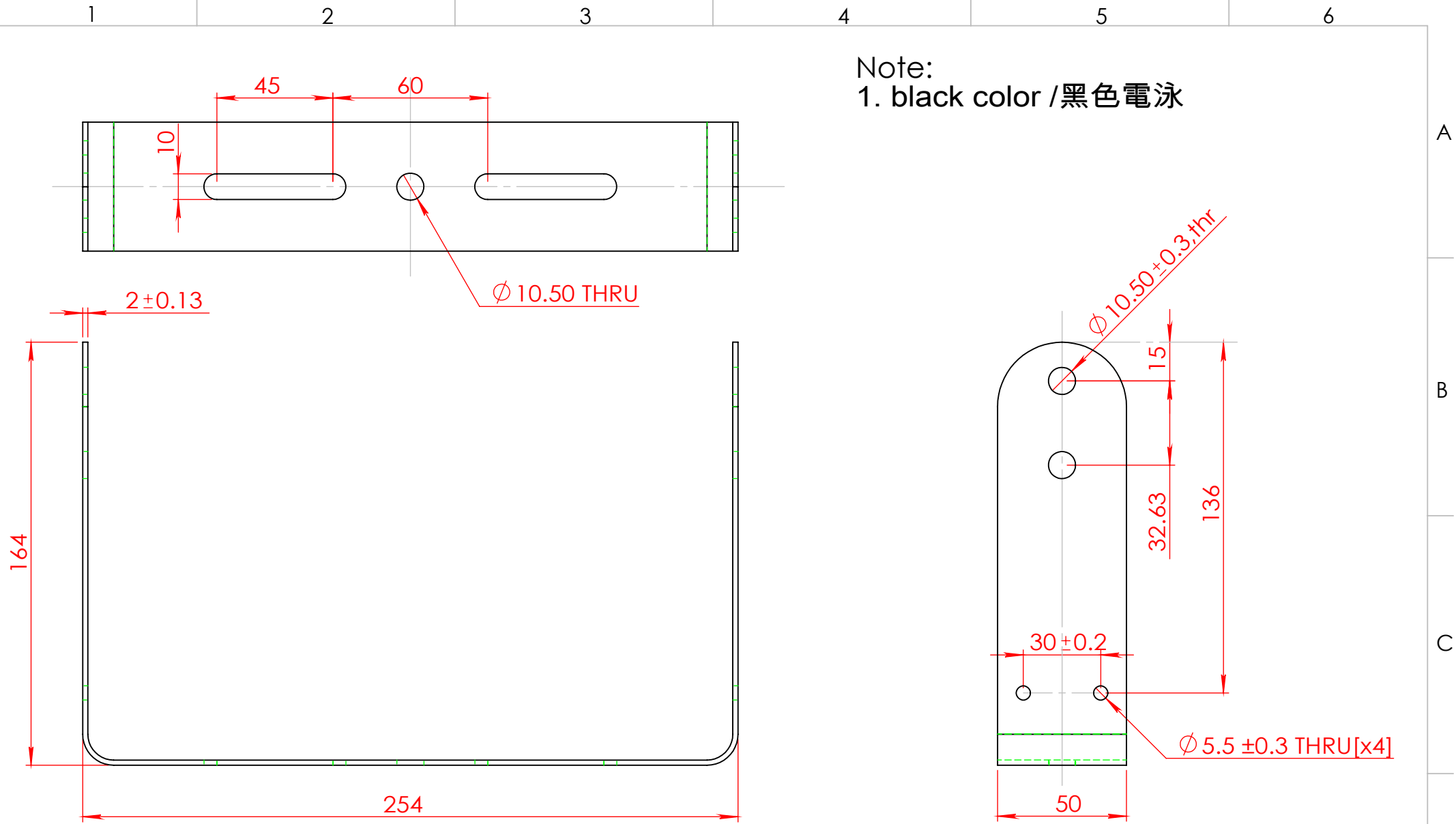
Note:
1. black color / 黑色電泳



 GlacialTech INC		MET.SPEC.	SUS201 T=2.0	UNSPECIFIED TOL'S	0.5-6 ±0.5 6-30 ±1.0 30-120 ±1.5 120-315 ±2.0	MODEL NO:	SS80 Plus
		UNIT	mm	DRAWING NAME		REV	SHEET
APPROVED BY		2017/11/13	 SCALE 1:2	DRAWING NO.		B	1/1
CHECKED BY		2017/11/13		SS80 Plus 1對1 U型支架			
DESIGN BY		2017/11/13	SIZE	A4	SS80P-01		
DRAWN BY	Justin	2017/11/13					

MARK	DESCRIPTION	DATE	APPROVED
2			
1			
	REVISION		

1 2 3 4 5 6

A

A

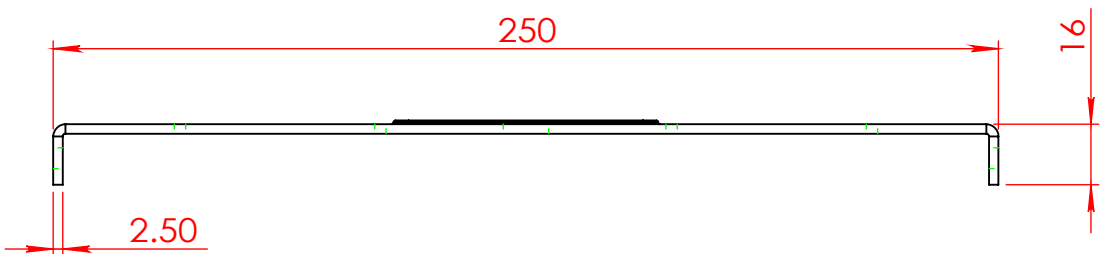

Note:
1. black color/黑色電泳

B

B

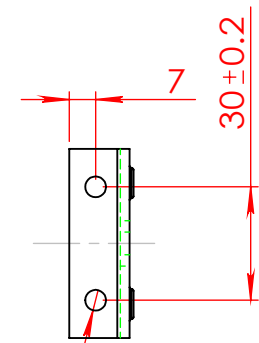
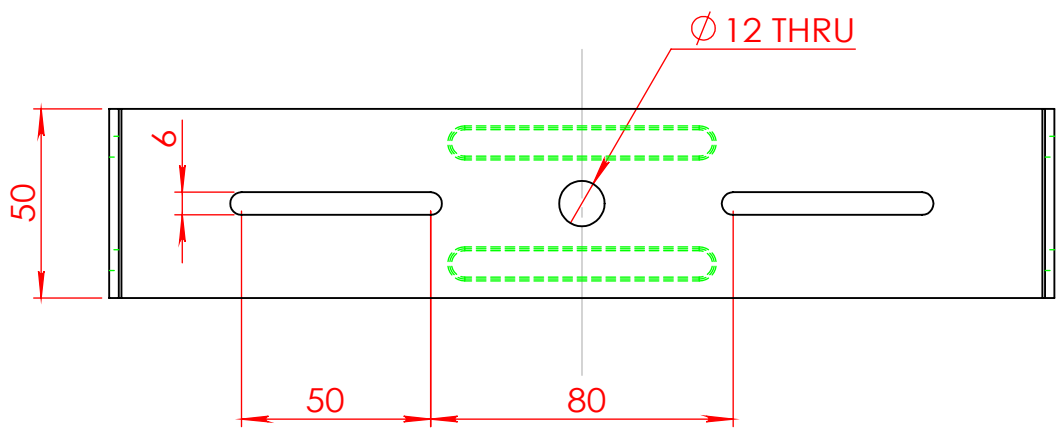

Ø 5.50±0.3, THRU[x4]

C

C

D

D

		MET.SPEC.	UNSPECIFIED TOL'S	MODEL NO:	
		SPCC T=2.5	0.5-6 ±0.5 6-30 ±1.0 30-120 ±1.5 120-315 ±2.0	SS80 Plus	
APPROVED BY	2017/11/13	UNIT	DRAWING NAME		
CHECKED BY	2017/11/13	mm	Driver Bracket for SS80 Plus Single Unit Kit		
DESIGN BY	2017/11/13	SCALE	SS80 Plus 1對1電源支架		
DRAWN BY	Justin	1:2	DRAWING NO.	REV	SHEET
	2017/11/13	A4	SS80P-02	A	1/1

MARK	DESCRIPTION	DATE	APPROVED
2			
1			
REVISION			

1 2 3 4 5 6

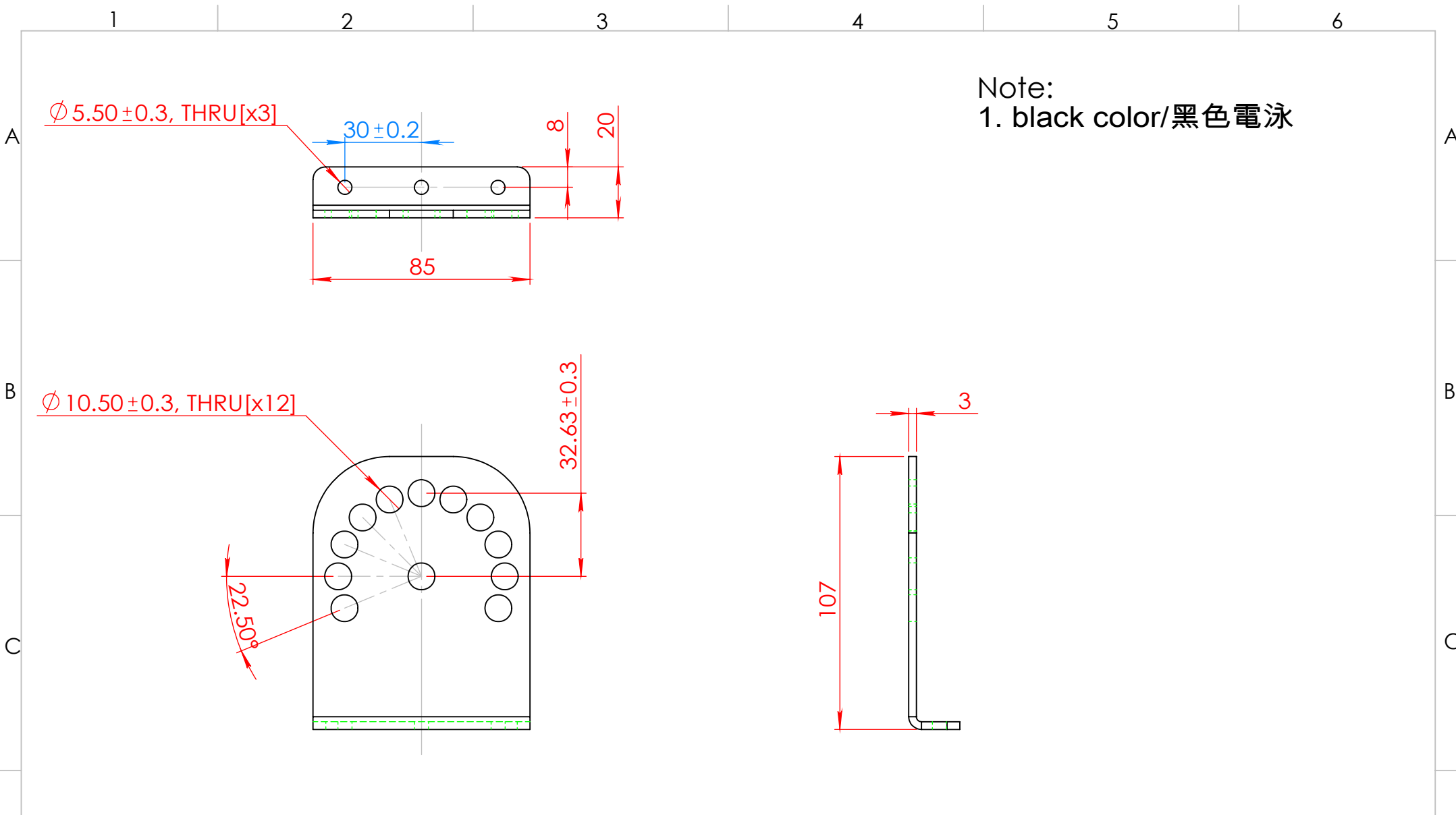

Note:
1. black color/黑色電泳

 GlacialTech INC				MET.SPEC.	AL1100 T=3.0	UNSPECIFIED TOL'S	MODEL NO:
				UNIT	mm	0.5~6 ±0.5 6~30 ±1.0 30~120 ±1.5	SS80 Plus
APPROVED BY		2017/10/24	DRAWING NAME				
CHECKED BY		2017/10/24	Heatsink Bracket for SS80 Plus Single Unit Kit				
DESIGN BY		2017/10/24	SS80 Plus 1對1散熱片側板				
DRAWN BY	Justin	2017/10/24	SCALE	1:2	DRAWING NO.	REV	SHEET
REVISION			SIZE	A4	SS80P-03	A	1/1

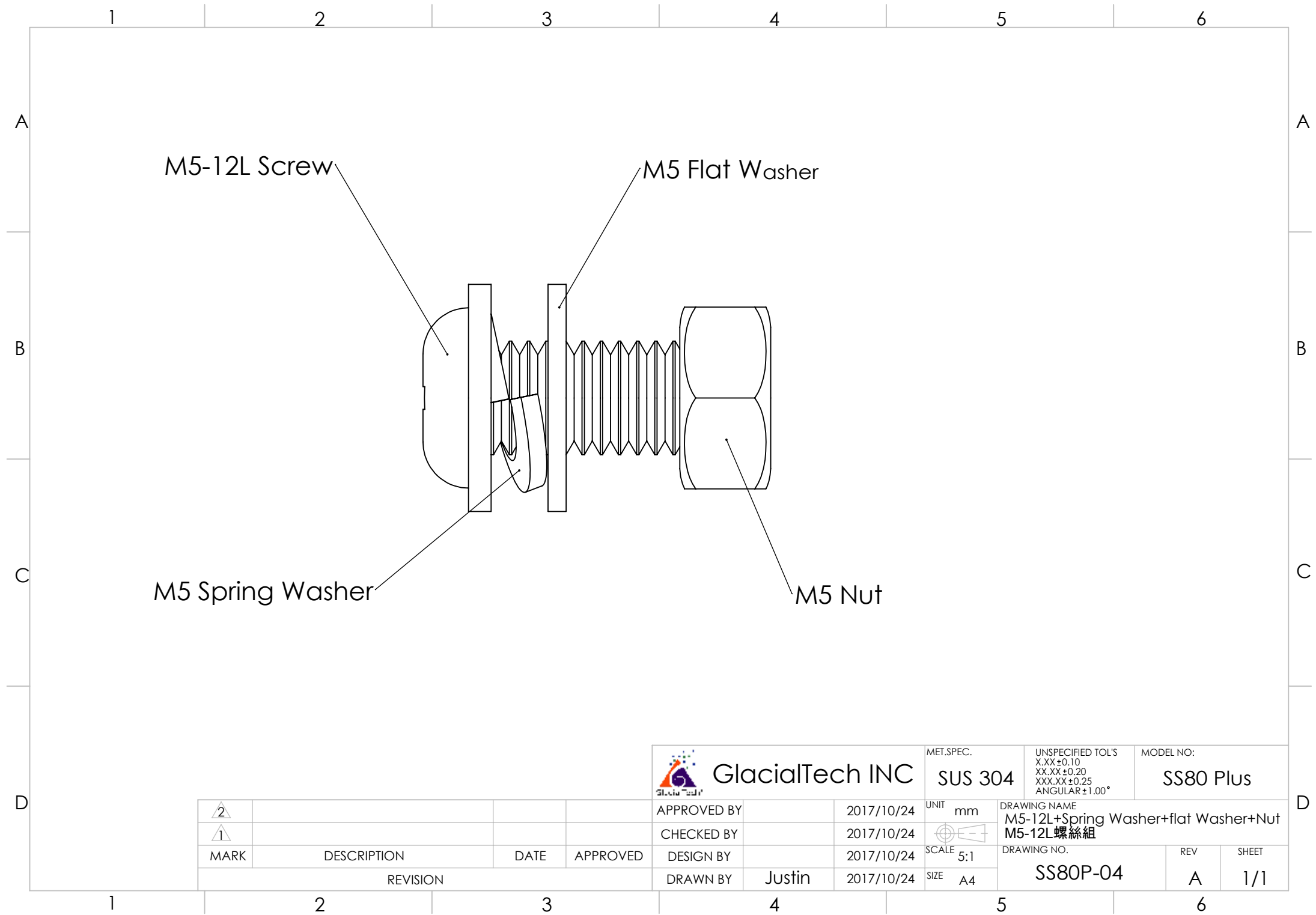

M5-12L Screw

M5 Flat Washer

M5 Spring Washer

M5 Nut

 GlacialTech INC		MET.SPEC. SUS 304	UNSPECIFIED TOL'S X.XX±0.10 XX.XX±0.20 XXX.XX±0.25 ANGULAR±1.00°	MODEL NO: SS80 Plus
APPROVED BY		2017/10/24	UNIT mm	DRAWING NAME M5-12L+Spring Washer+flat Washer+Nut M5-12L螺絲組
CHECKED BY		2017/10/24	SCALE 5:1	
DESIGN BY		2017/10/24	SIZE A4	DRAWING NO. SS80P-04
DRAWN BY	Justin	2017/10/24		REV A
				SHEET 1/1

MARK	DESCRIPTION	DATE	APPROVED
2			
1			
REVISION			



M5-16L Screw

M5 Flat Washer

M5 Spring Washer

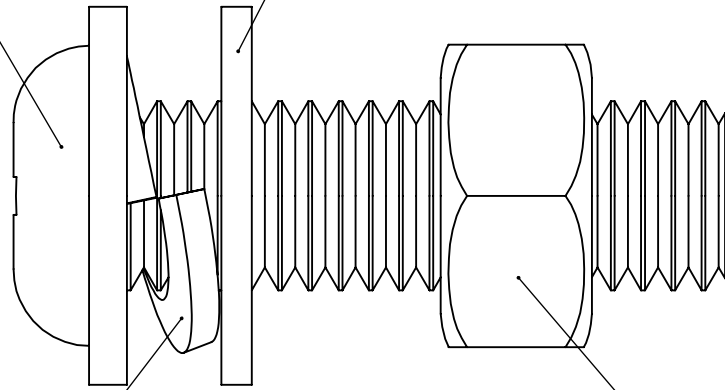
M5 Nut



 GlacialTech INC				MET.SPEC.	UNSPECIFIED TOL'S	MODEL NO:	
				SUS304	X.XX±0.10 XX.XX±0.20 XXX.XX±0.25 ANGULAR±1.00°	SS80 Plus	
APPROVED BY		2017/10/24	UNIT	mm	DRAWING NAME		
CHECKED BY		2017/10/24			M5-16L+Spring Washer+Flat Washer+Nut		
DESIGN BY		2017/10/24	SCALE	5:1	DRAWING NO.		
DRAWN BY	Justin	2017/10/24	SIZE	A4	SS80P-05	REV	SHEET
REVISION					A	1/1	

MARK	DESCRIPTION	DATE	APPROVED
2			
1			

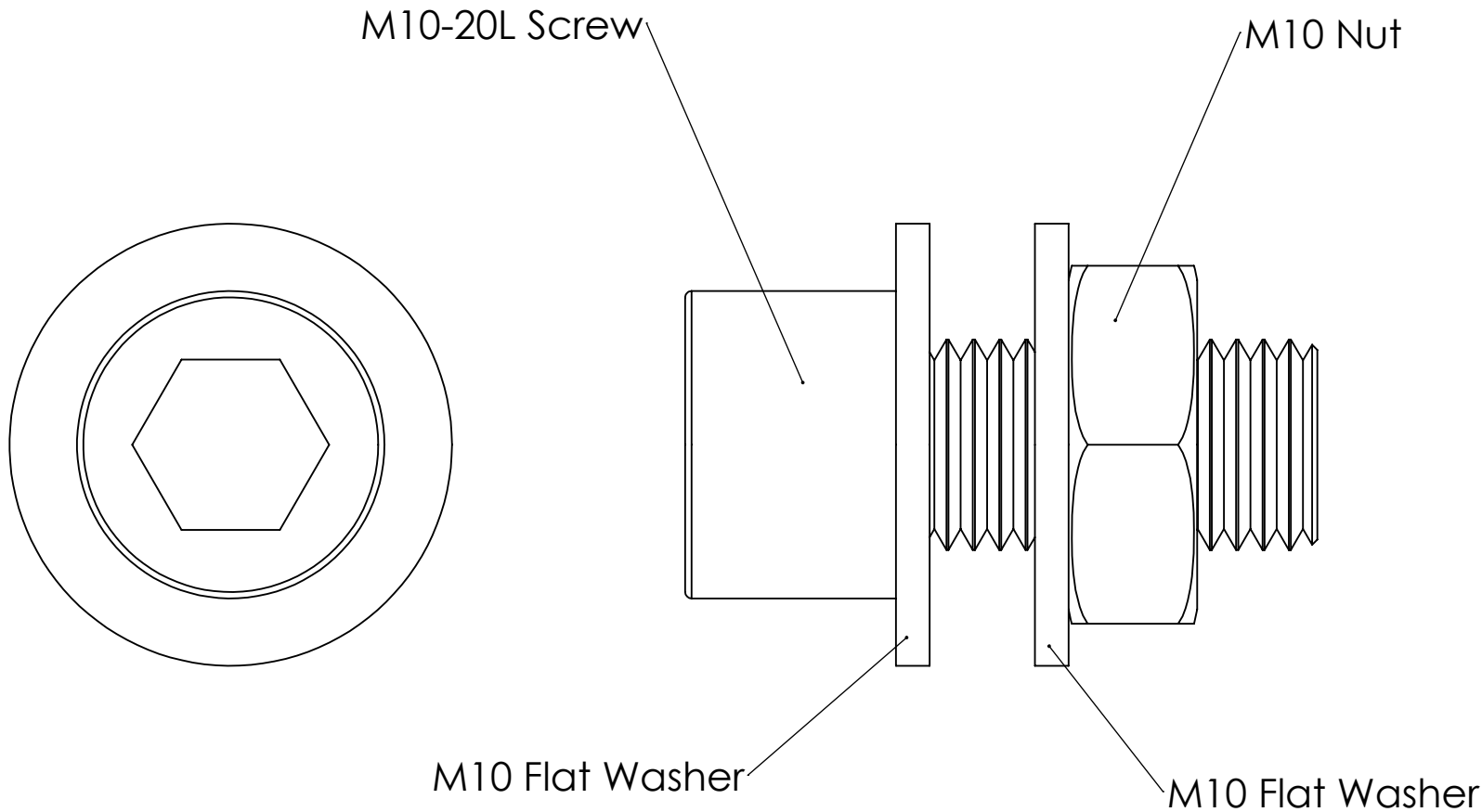

 GlacialTech INC		MET.SPEC. SS304	UNSPECIFIED TOL'S X.XX±0.10 XX.XX±0.20 XXX.XX±0.25 ANGULAR±1.00°	MODEL NO: SS80 Plus
APPROVED BY		2017/10/24	UNIT mm	DRAWING NAME M10-20L+Flat Washer(x2)+Nut M10-20L螺絲組
CHECKED BY		2017/10/24	SCALE 3:1	
DESIGN BY		2017/10/24	SIZE A4	DRAWING NO. SS80P-06
DRAWN BY	Justin	2017/10/24		REV A

MARK	DESCRIPTION	DATE	APPROVED
2			
1			
REVISION			