

REV	DESCRIPTION	APPROVED	DATE
A	NEW		9/30/2016

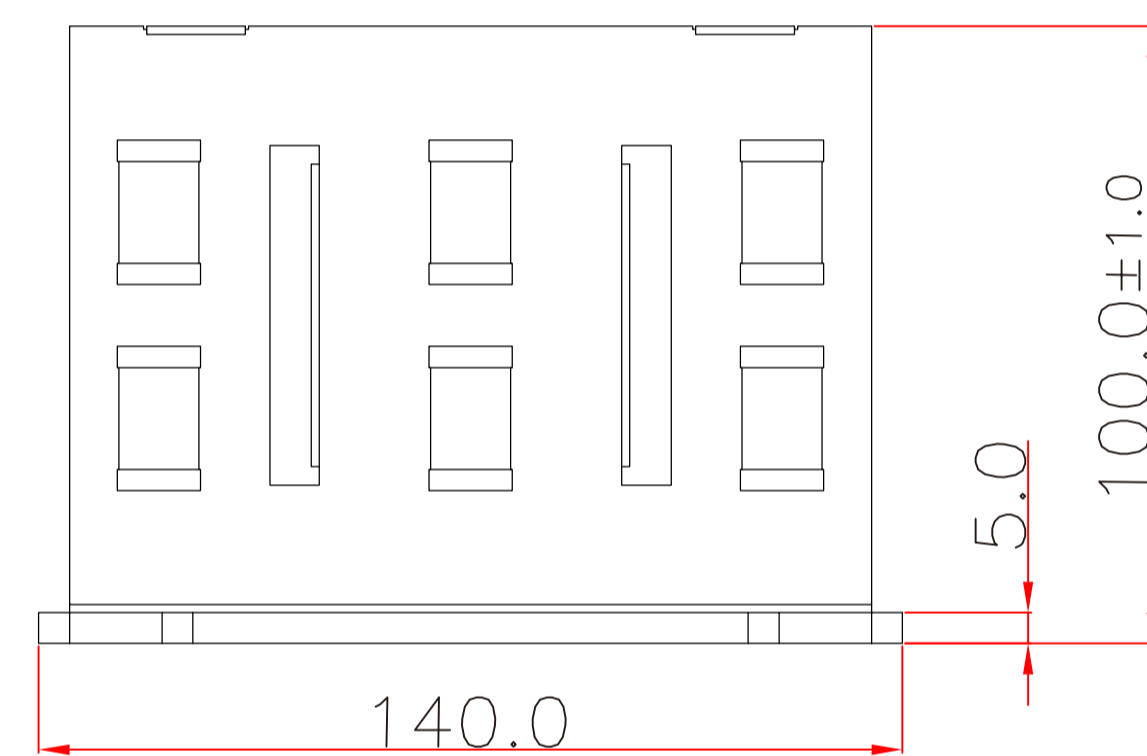

NOTE:

1. The number of fins 45pcs
2. The size difference of A should not be greater than 1mm
3. Surface treatment : Electrodeposition process
4. Can not have burrs, scratches, dirt, color, excess glue
5. Fin can not have significantly skew, variations, unglued
6. All material objects, surface treatment, thermal plastic must adhere to ROHS standards
7. Fin and the bottom weld, impact strength test shall by 1kg ball

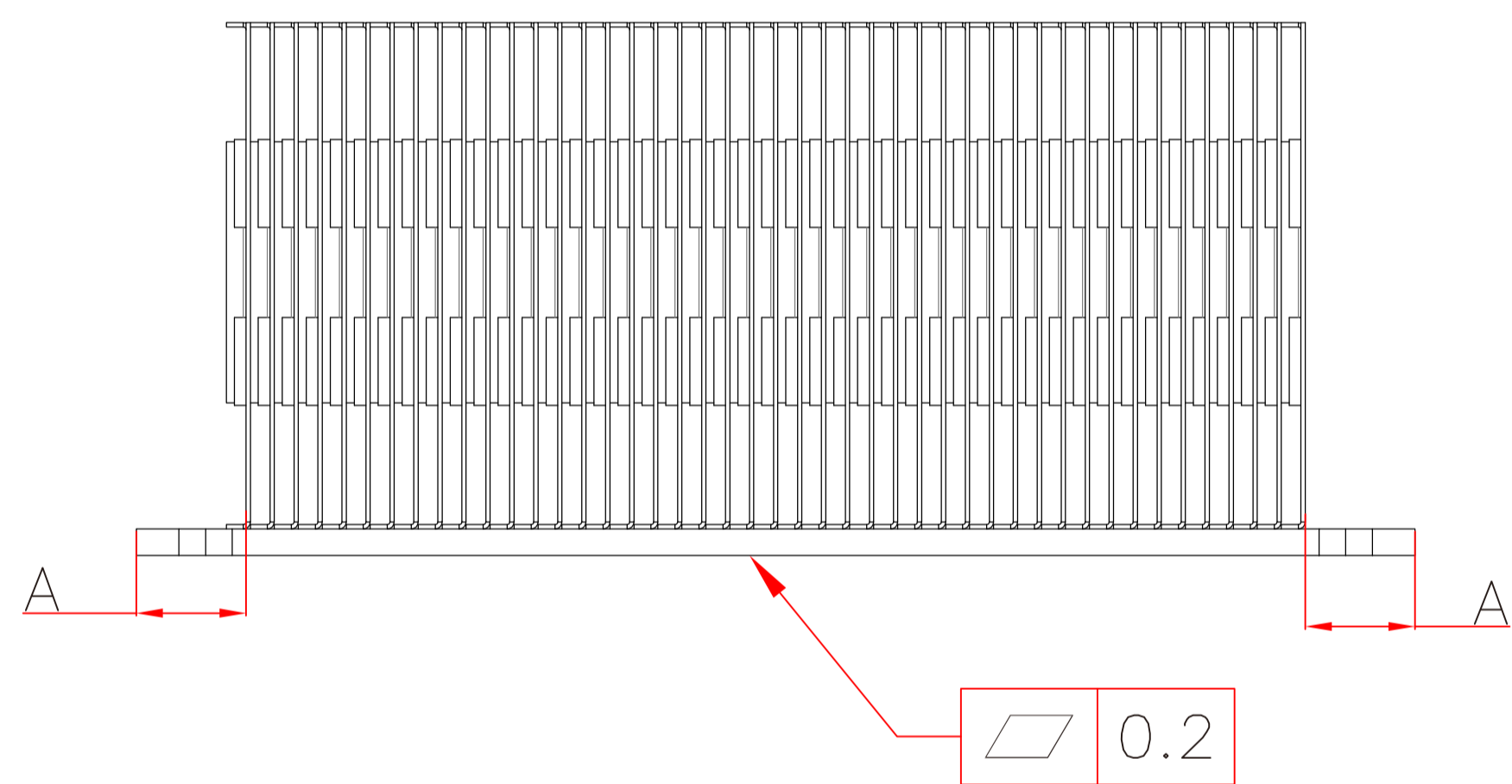
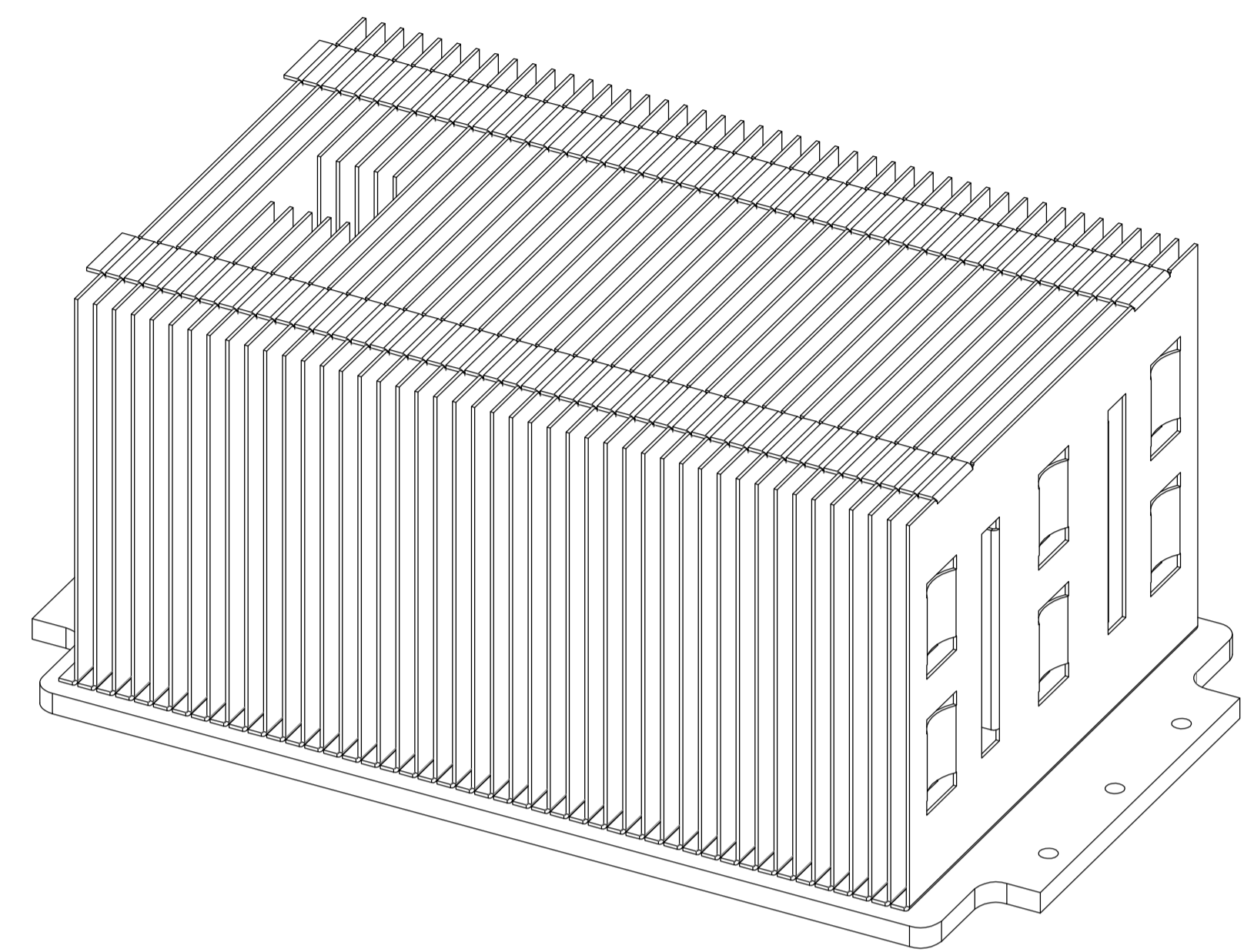
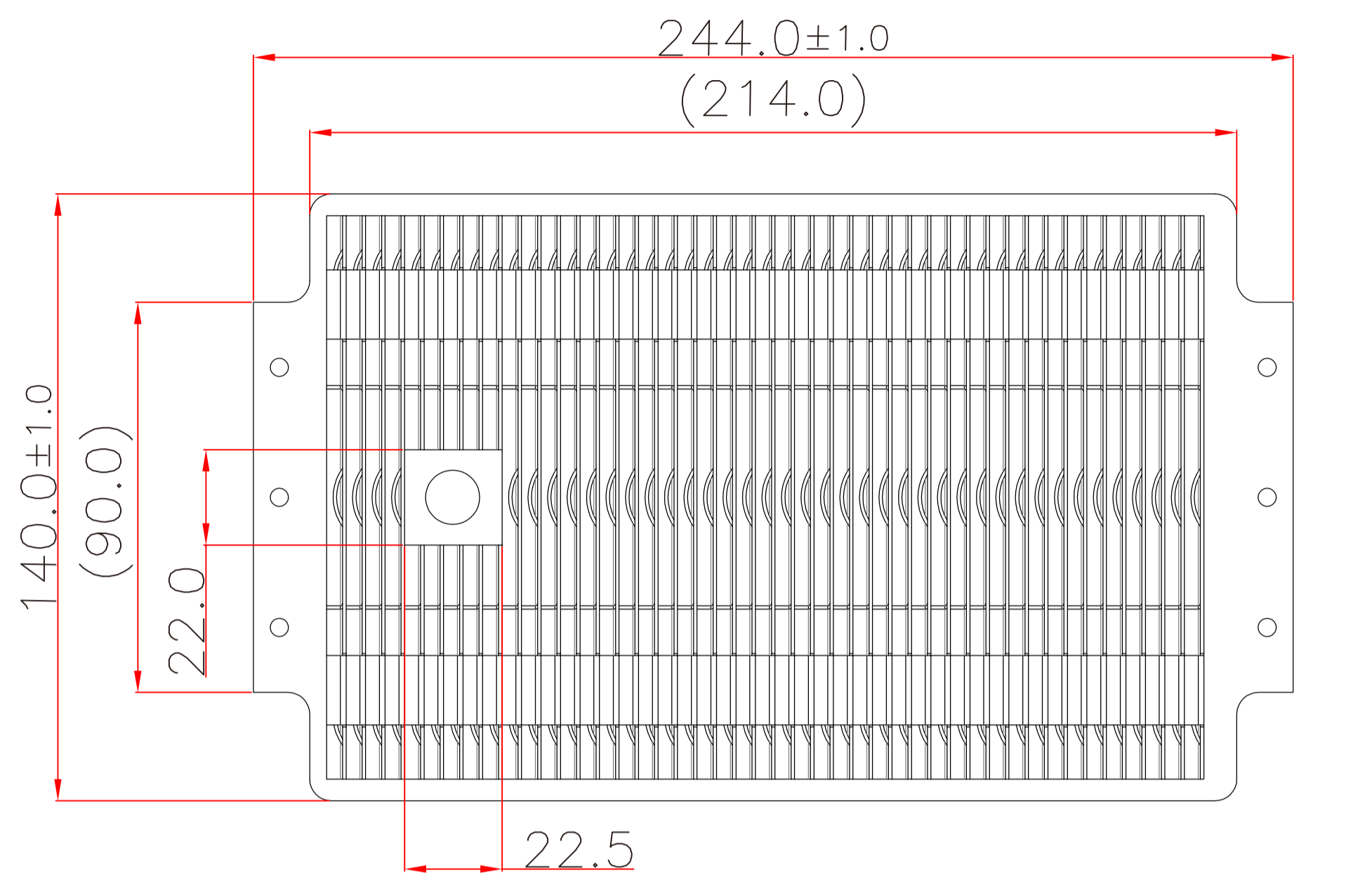
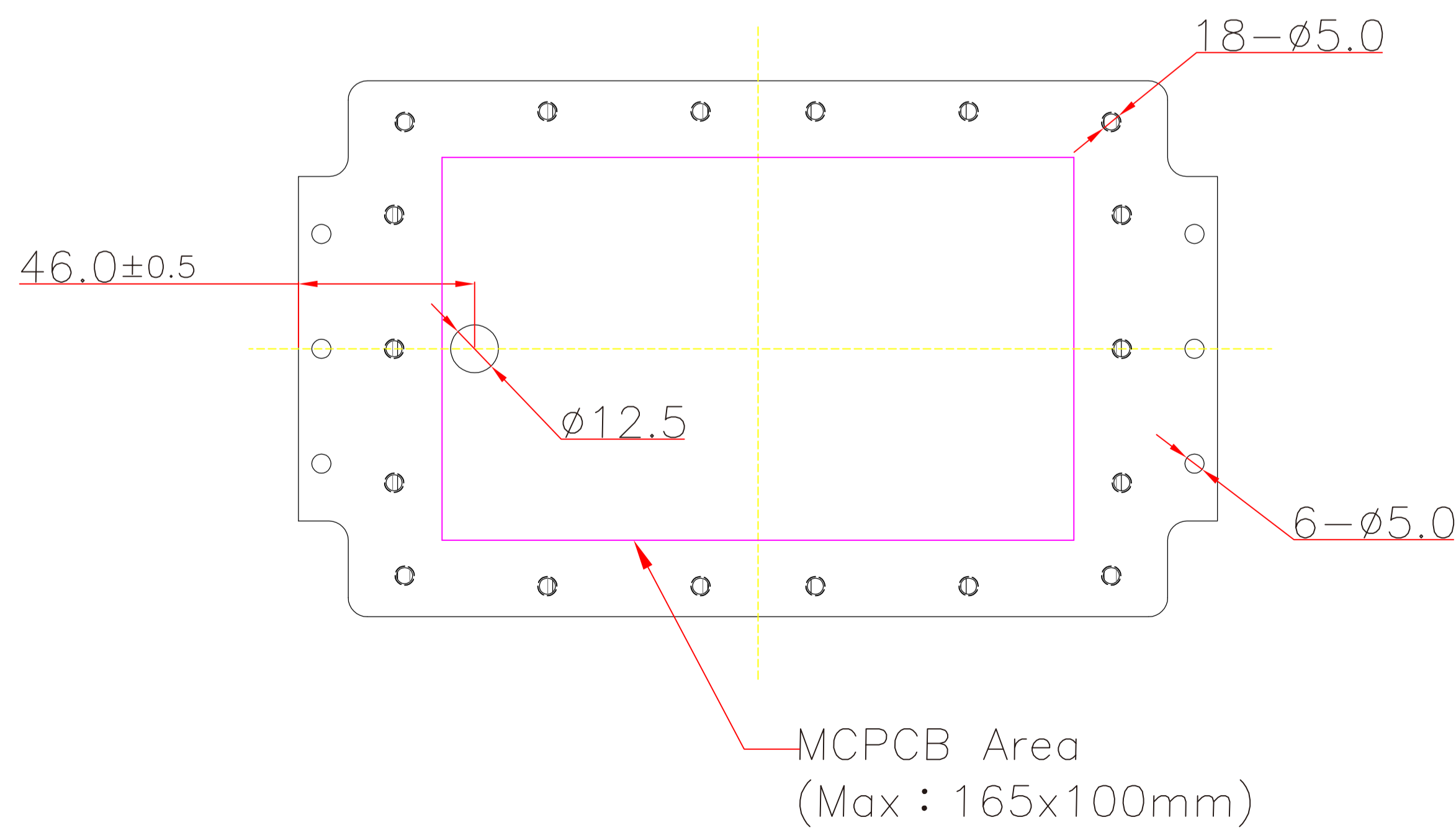

MATERIAL: AL5052+AL1050				Finish Electrophoresis			
				PART NO. CT-SS080P00AB0001			
DIM.	TOL.	Matel	Plastic	USER	UNIT:mm	SCALE: 1/2	DWG NO. RF03-24
0 ~ 6		0.10	0.10		DRAWN: 9/30/2016		
6 ~ 30		0.15	0.15		CHECKED:		
30 ~ 120		0.20	0.25		APPROVED:		
120 ~ 300		0.25	0.40		SIZE: A3		
300 ~ 600		0.40	0.60		SHEET 1 OF 1		
600 ~ 1200		0.70	0.80				
MATERIAL		1'					